

CHAPTER 8

CONSTRUCTION SURVEYS

Construction Control Points	8-2
Hub Lines	8-2
Temporary Right-of-Way Staking	8-3
Slope Staking	8-4
Blue Top Staking	8-7
Paving Hub Staking	8-8
Pipe Staking	8-9
Bridge Staking	8-10
Public Land Survey System Corners	8-16
Right of Way and Property Corners	8-19
Undercut Volumes	8-20

LIST OF FIGURES

Figure 8-1	Grade stake marking	8-2
Figure 8-2	Temporary right of way lath	8-3
Figure 8-3	Slope staking X-section	8-5
Figure 8-4	Slope definition	8-5
Figure 8-5	Slope stake calculation	8-6
Figure 8-6	Slope stake marking	8-6
Figure 8-7	Blue top locations	8-7

CONSTRUCTION CONTROL POINTS

Construction control points are the primary control points set and used for the preliminary survey phase of the project and can be obtained from the appropriate SDDOT Area Office. The northing, easting and elevation shall be checked on all control points prior to use for construction surveys. In the event it is necessary to adjust the northing, easting and elevation or install additional control points to facilitate construction staking, the procedures outlined in Project Control - Chapter 3 of this manual shall be followed.

HUB LINES

Hub stakes (2" x 2" x 8" or similar) are set on both sides of a roadway, driven flush with the existing ground in proximity to the right of way line or at a specified distance beyond the work limits to prevent them from being disturbed by construction activities.

Grading stakes (1" x 2" x 12" or similar) shall be placed behind the hub and marked with the cut or fill from the top of the hub to the top of the designed dirt subgrade at the hinge point (The point where the roadway meets the top of the inslope under the surfacing layers) on the face of the stake facing the alignment. The station offset and direction right or left from the design alignment will be marked on the face of the stake facing away from the alignment. ([Figure 8-1](#))

A guard lath (3/8" x 1-1/2" x 48" or similar) will be placed beside the grading stake and marked with the station, offset and direction right or left from the design alignment. Care should be taken in placing the lath so the information on the grading stake can be read without removal of the guard lath.

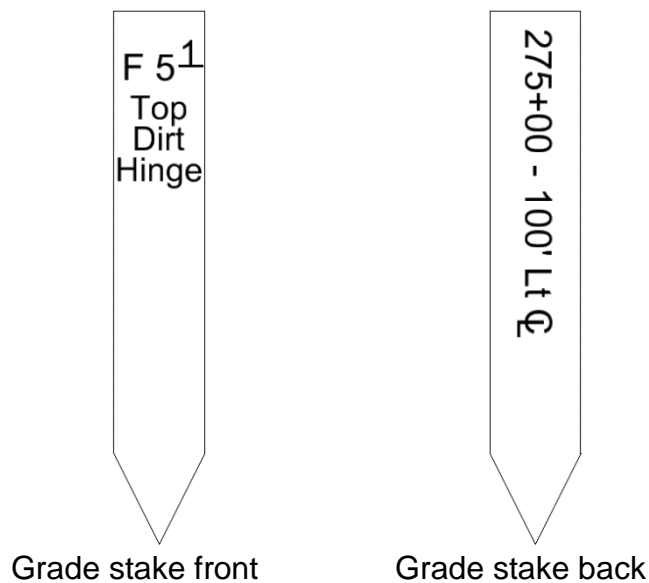

Figure 8-1 Grade stake marking

TEMPORARY RIGHT-OF-WAY STAKING

Lath (3/8" x 1-1/2" x 48" or similar) will be set along the right of way line marked R.O.W. Line along with the station, offset and direction right or left from the design alignment on the face of the lath facing the alignment ([Figure 8-2](#)). When completed this lath line delineates the boundary between private property and the highway right of way. Under no circumstances should this line be crossed by any machine, construction personnel or SDDOT staff without prior written permission from the private landowner, unless temporary easement for construction purposes was acquired on the private property adjacent to the right of way.



Figure 8-2 Temporary right of way lath

SLOPE STAKING

Slope stakes were traditionally set using an auto level and 200' surveyor's tape (plastic, nylon or steel). Modern day slope staking is performed using survey grade GPS or robotic total station equipment allowing the surveyor to enter alignment, cross section and terrain model data into a data collector and slope stake any alignment station along the project to dirt grade.

a. Catch Point

The point where the roadway backslope intersects the existing ground within a cut section and the point where the inslope intersects the existing ground within a fill section is commonly referred to as the "catch" ([Figure 8-3](#)). This point is typically shown on the cross sections within Section X of the construction plans with an elevation and offset distance right or left from the alignment stationing.

b. Hinge Point

The point where the roadway meets the top of the inslope under the surfacing layers (concrete, asphalt and gravel) is commonly referred to as the "hinge" ([Figure 8-3](#)). This point is typically shown on the cross sections within Section X of the construction plans with an elevation and offset distance right or left from the alignment stationing.

c. Try Distance

The distance from the alignment to the designed catch point is commonly referred to as the "try" distance ([Figure 8-3](#)). This distance is typically calculated using the cross sections within Section X of the construction plans.

d. Plus Distance

The horizontal distance from the alignment to the designed toe of the backslope is commonly referred to as the "plus" distance ([Figure 8-3](#)). This distance can be calculated using the typical grading sections within Section B of the construction plans.

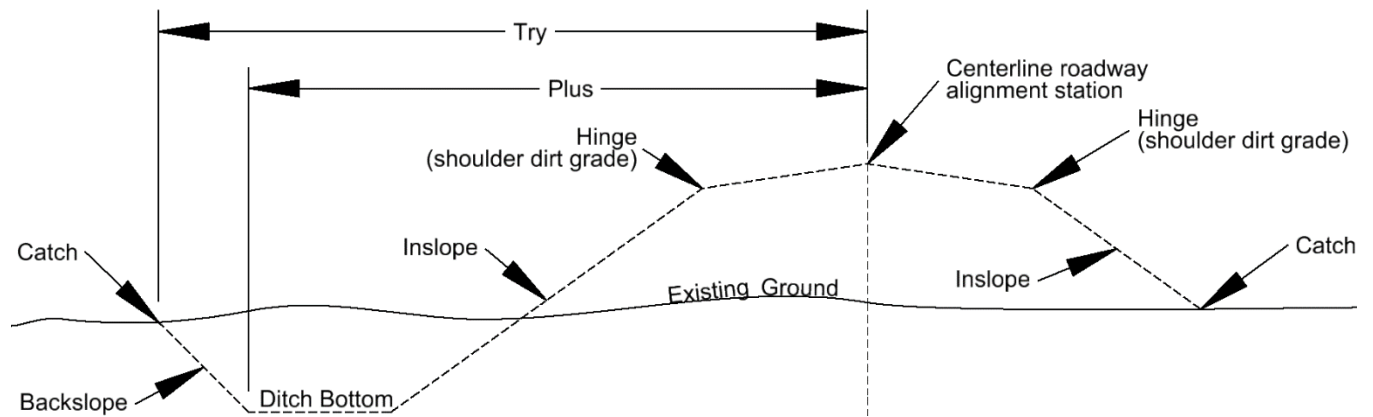

Figure 8-3 Slope staking X-section

There are three types of slopes on a typical cross section: backslope, inslope and ditch bottom slope ([Figure 8-3](#)).

The angle of the backslope and inslope are given as a ratio, such as 5:1 or 4:1. The first number is commonly referred to as the “run”; it indicates the number of feet the slope must “run” horizontally to maintain the desired slope. The second number is commonly referred to as the “rise”; it indicates the number of feet the slope must “rise” vertically to maintain the desired slope.

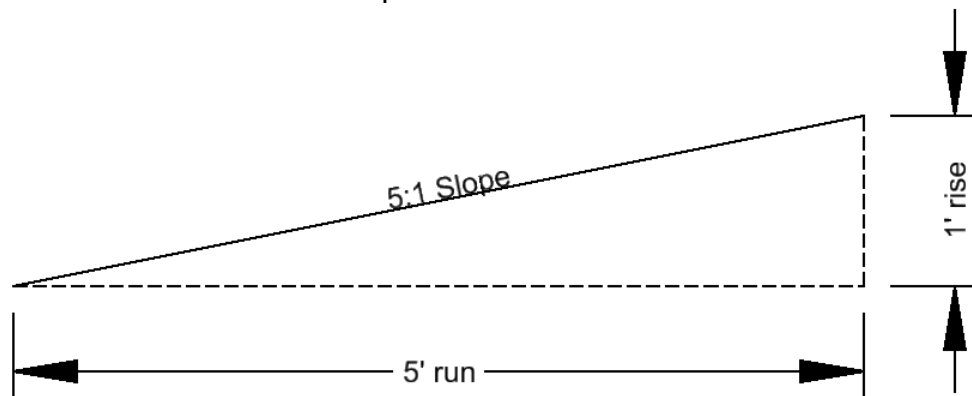

Figure 8-4 Slope definition

When calculating slope stakes in a cut section, the difference in elevation between the original ground at the calculated “try” distance and the designed elevation at the toe of the backslope is multiplied by the “run” of the slope rate. For example, the cut calculated at the “try” distance of 99.0 feet is 5.6, the slope rate of the backslope is 5:1 and the “plus” distance is 70.0 feet ($5.6 \times 5 = 28.0$ feet + 70.0 feet = 98.0 feet). The adjusted calculated “try” distance is 98.0 feet. Move toward the alignment centerline to 98.0 feet from the alignment and check the cut at the adjusted “try” distance. The actual “catch” is found when the calculated “try” distance matches your distance from the alignment

(Figure 8-5). Repeat this “try” process until the adjusted calculated “try” distance matches your distance from the alignment.

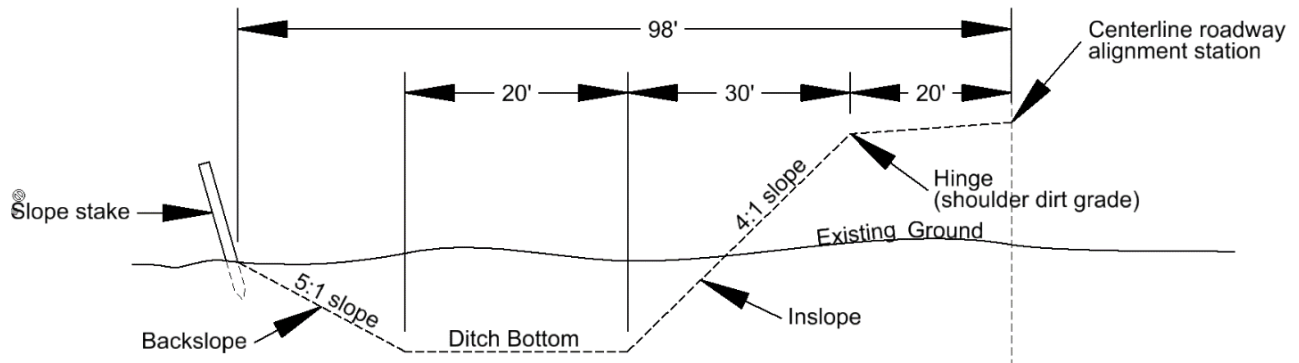

Figure 8-5 Slope stake calculation

When the actual “catch” is found the slope stake (1” x 2” x 12” or similar) shall be marked and driven into the ground at the “catch” point facing centerline. Care should be taken to properly angle the slope stake so that it can be read by the equipment operator as he passes by without getting off the equipment.

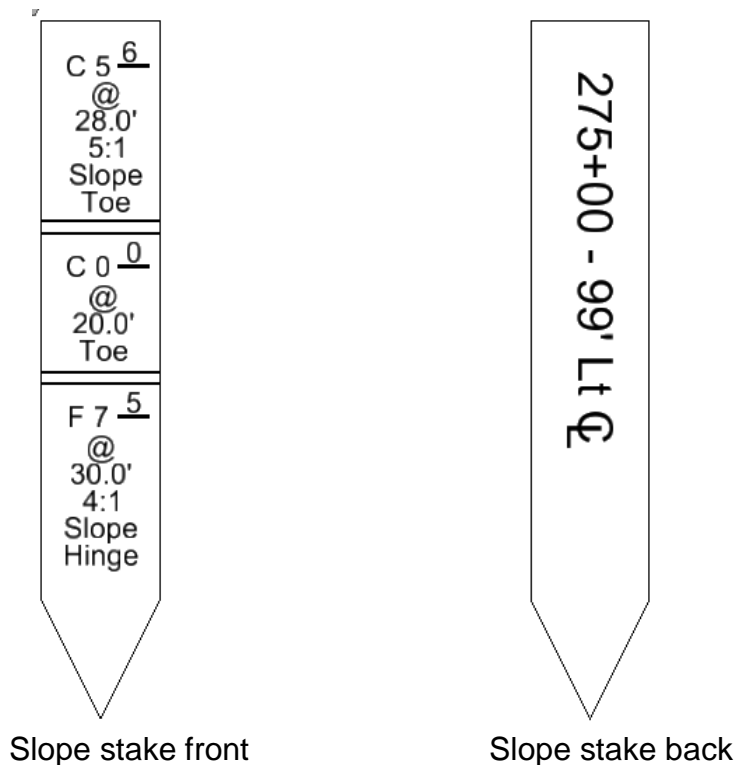

Figure 8-6 Slope stake marking

Slope stakes when properly marked should read like a story and give instructions on how to build the ditch section from the “catch” to the “hinge” of the roadbed. Figure 8-6 reads as follows:

cut 5.6 feet at 28.0 feet 5:1 slope to toe of backslope
then from that point
cut 0.0 feet at 20.0 feet to toe of inslope
then from that point
fill 7.5 feet at 30.0 feet 4:1 slope to “hinge”

BLUE TOP STAKING

After the subgrade has been gravel base course shall be installed compacted and trimmed as close to grade as possible. Stakes referred to a blue tops (1” x 1” x 6” or similar) are driven into the gravel base course so their tops are set to the elevations called for on the plans. The contractor then shaves away or fills in gravel base course until the gravel surface of the roadway is in line with the tops of the blue top stakes.

Blue top staking shall be completed using the following equipment:

- a. Auto level, level rod and surveyors tape
- b. robotic total station.

Two operations are needed to install blue tops by the level and rod method. The first operation involves running in roadway alignment and setting out the stakes. The second is the grading of the stakes.

Running in the roadway alignment is accomplished by setting roadway control points for the blue topping area, then installing blue top stakes on centerline and at given offsets. Generally, blue tops are set for every station and midpoint between stations.

Once the centerline blue tops have been set, the next step is to lay out the blue top stakes across the roadway, so they can be set to grade (top of gravel surface). These stakes are set on the centerline and on each shoulder for every station and midpoint between stations. On a wide roadway, stakes are also placed at the quarter points ([Figure 8-7](#)).

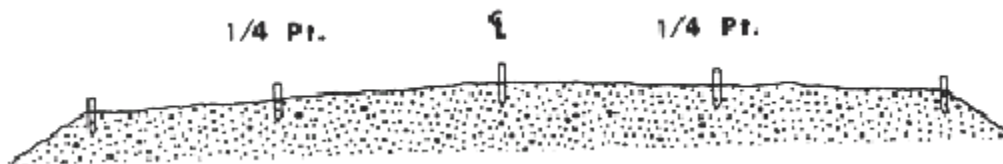

Figure 8-7 Blue top locations

The edge of the driving lane is usually called the quarter point because it is about half way between the shoulder and centerline. These extra stakes will reduce or eliminate

high or low spots between centerline and shoulder blue tops set on wide roadways finish the gravel surface to the correct elevations.

The party chief will have a set of blue top notes that give the distances from centerline out to where each stake is to be set. The transverse distances are measured to the nearest tenth of a foot. Once the proper location for each blue top has been found for this section, a blue top stake is tapped into the gravel surface just deep enough so that the stake will not be easily bumped out of location. The stakes are left intentionally high, as their exact depth will be established later.

Setting the stakes at right angles to the centerline is a very important part of the entire operation, especially if the roadway is on a steep grade. If the stakes are not set at right angles to the centerline, the roadway (at that location) will be built either higher or lower than it should be. This error causes a change in the cross-slope of the roadway and can cause a wavy effect in the grade line.

After the stakes are laid out the survey crew grades them to their required elevations. The cut or fill will be given in hundredths of a foot. Blue tops tolerances are - 0.02 feet to +0.08 feet from the design elevations is used. To set these stakes accurately, the instrument person must have accurate shots. The rod person helps to get this accuracy by using a rod level or by rocking the rod when giving him a check shot.

When the instrument person takes the check shot he/she will determine if the stake is at the right elevation or if some cut or fill is still needed and how much it is. If more cut is needed, the blue top can be driven deeper. But if fill is needed, the stake must be pulled, and the process is started over again.

A “guard lathe” will be placed next to the blue top stake. The contractor uses these during his finishing operations to find the blue top. Without them, there’s a good chance that the blue top will be knocked out or lost.

PAVING HUB STAKING

Paving hubs are stakes that are used to reference line and grade for concrete pavements and curb and gutter. The paving hubs are also used to establish trimming elevations, prior to paving, and the location of dowel baskets in PCC Pavement. They are installed at regular intervals along the roadway, usually at transverse joint locations, and just outside the area to be paved.

The contractor may request paving hubs at specific offsets so that his workers and/or machinery can properly reference the stakes without damaging them. The contractor may also request that the stakes give either “projected grades” or “flat grades”. A projected grade is a theoretical elevation that the pavement *would* be at if it were to extend all the way to the paving hub. A flat grade gives an actual elevation difference from the stake to the top edge of pavement or top of curb and gutter. It is important that

the type of grade the contractor is requesting is clearly communicated, as the difference between these two elevations is often significant

Paving hubs are useful to both the contractor and the inspector in that the contractor uses them to control the operation of his equipment or to set forms, while inspectors use them to check what the contractor is building to see that it is correct.

The hubs you will be putting in for this line are either a long nail (with tassel) driven flush with the ground or a wooden stake with a tack driven in the top. The top of nail or top of tack are shot and used as the reference for the grade given to the contractor. Grades can be communicated with the contractor in many ways. Two common ways are to drive a 1"x 2" directly beside the nail (tack) with the elevation written, or to drive the nail through a heavy white ribbon that can be written on. Stationing should be written periodically so that the contractor, inspector, and survey crew can keep track of location.

PIPE STAKING

a. General

DOT-214 states where the pipe will go and how it should be installed. It is also a record used to pay the contractor for installation. The plans contain installation information. One DOT-214 shall be used for each pipe.

Note the appropriate project and other information on the title page. The station where it is to be installed identifies each pipe on a project. The INSTALL information is type of pipe, size, length, ends, and skew. This information can be found in the project plans. Any additional information can be entered under additional notes.

There are three types of bedding, Class A, Class B, and Class C. This also can be found on the plan sheets. Class C is the most common bedding and is used when no bedding is included on the plan sheets.

The methods used to backfill a pipe are normal or imperfect trench. Normal backfill is the usual method unless noted in the project plans.

The distances right and left of centerline are obtained from cross sections. The distances shown are to the end of the end sections.

b. Reference Stakes

The hub and reference stake for pipes should be offset from the end of the pipe section and not the end of the flared end or safety end. There will be two stakes at each end of the pipe:

- 1) The hub, which is the reference point, shall be driven flush with the ground and far enough from the pipe site to insure protection during construction.
- 2) The guard stake, which will be placed alongside the hub, will contain the following information:
 - a) Offset distance
 - b) Stationing
 - c) Pipe size
 - d) Length of pipe
 - e) Type of pipe
 - f) Number of flared or safety ends
 - g) Cut or Fill to flow line at end of pipe

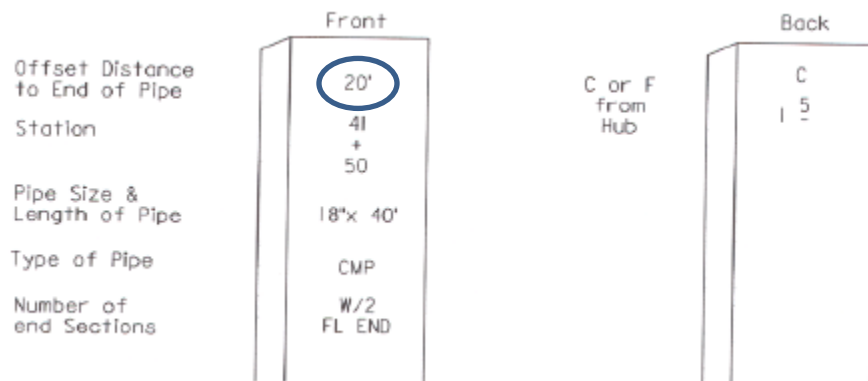

From this example, the information can be determined from the guard stake:

- a) It is 20 feet to the end of the pipe
- b) The pipe is at Station 41+50
- c) It is an 18 inch by 40-foot CMP type pipe with 2 flared ends
- d) The hub is 1.5 feet higher than the flowline at the end of the pipe.

BRIDGE STAKING

a. General

Make a set of notes while making the plans review. They will be used when staking a structure, and again during construction. These notes should begin at abutment or sill number 1 and proceed through each bent to the end abutment or sill. The information shown for each foundation unit should include:

- i) Sketch of each unit
- ii) Dimensions of each unit

- iii) Distance from bridge centerline to the center of each unit
- iv) Stationing of each unit
- v) Base of footing elevation
- vi) Top of footing elevation
- vii) Top of column elevation
- viii) Top of column elevation

- i) Distance from mainline centerline to bridge centerline (if applicable)
- ii) Benchmark information (elevation and location)

Staking is done from the centerline of abutments or the work line on sills. Check the plans for the distance from begin or end bridge.

Only one abutment or sill, and one or two bents, should be placed on each sheet of notebook paper. This will allow room for sketches, elevations, stationing, etc.

b. Reference Stakes

Reference stakes are of great importance for the proper construction of a bridge. They must be accessible and accurate. Some common staking practices are listed below:

- i) Check all dimensions on the plans before staking.
- ii) Check alignment and stationing of the structure centerline. The structure must fit the proposed construction site. For example, on crossovers the stationing must check with the crossroad or railroad centerline. Have any changes occurred at the site, which may influence the location of the structure or method of construction, such as washouts, flooding, or channel changes.
- iii) Set an adequate number of reference points.
- iv) Check accuracy of staking by measurements and cross measurements.

Two permanent points should be set beyond each abutment or sill. The first point should be set at an even distance, such as 100 feet, from the centerline of an abutment or the work line of a sill. The second point should be 500 feet beyond the first point. It should be far enough so as not to be disturbed by construction processes.

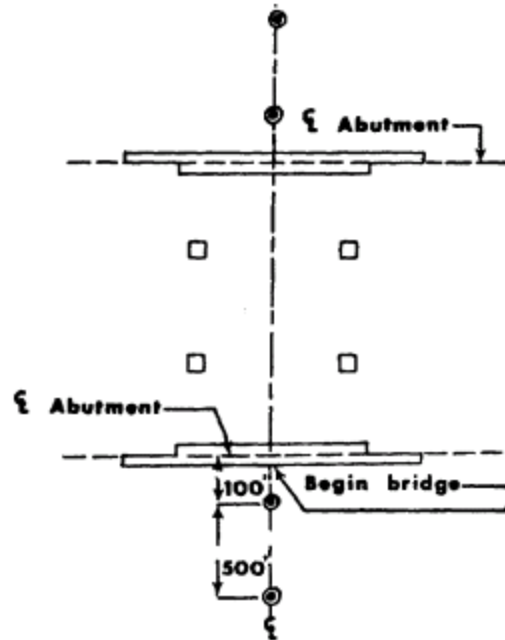

Set enough reference points to insure replacement, should one become damaged, or if it is known that a point will be disturbed, such as an approach fill.

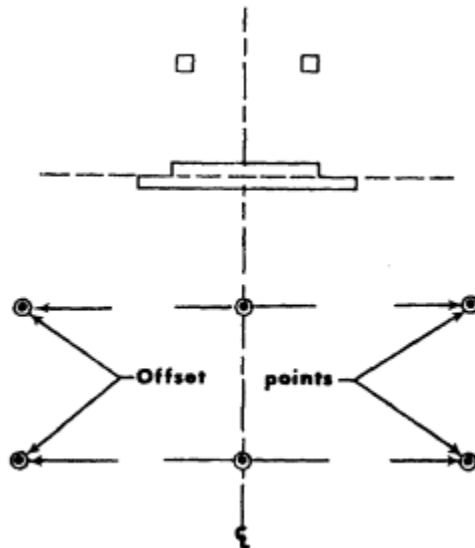

Reference point should be placed on the roadway centerline at the point where centerline of each bent and abutment or work line of a sill crosses the centerline. This may not be possible on stream crossings but set any that would be on dry land. All

these points should be set on a dry land structure. Stake the centerline of a bridge in instances where the centerline is not on the centerline of the road.

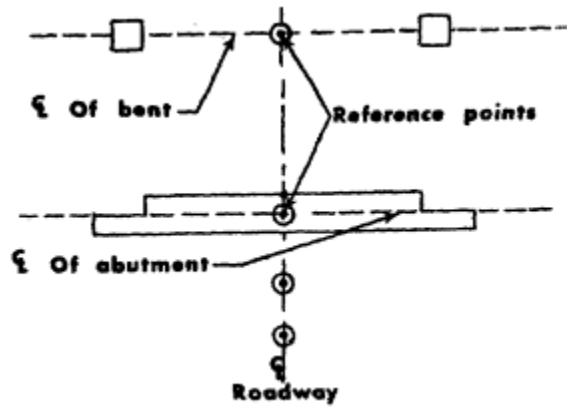

A minimum of two offset points should be set left and right of each bent or abutment reference point. These offset points should be set at right angles to the roadway centerline on straight bridges.

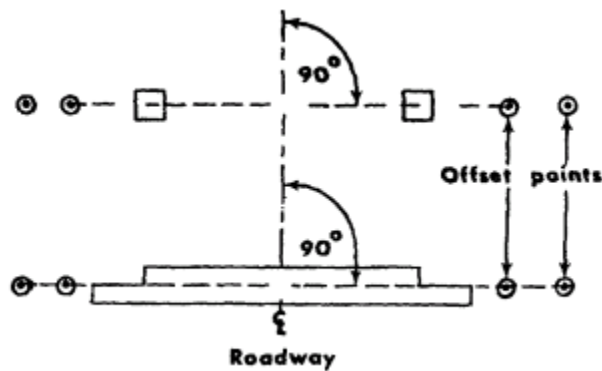

When the structure is to be built on a skew, these offset points should be set in relation to the skew.

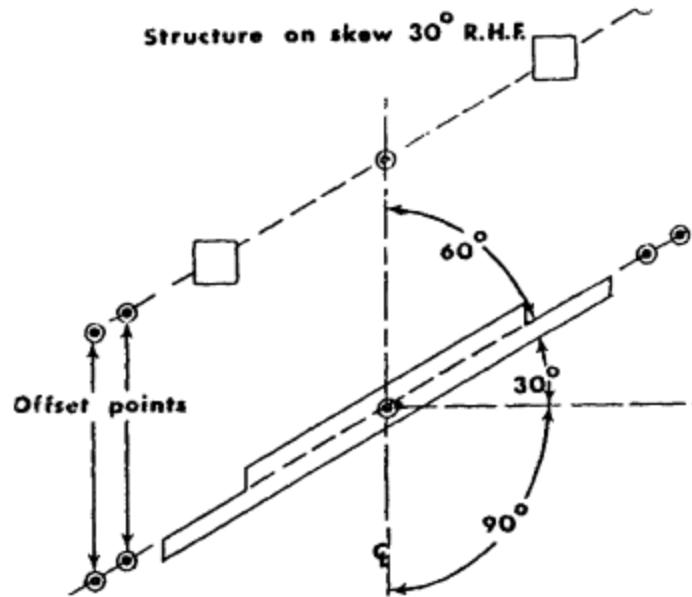

When setting offset stakes on a bent, place a stake or nail in the exact center of each footing (if it is not under water). This will mark the footing location for taking cross sections at a later time. Reference points or offset stakes are usually 2" x 2" x 14" wood stakes driven flush with the ground. A tack or small nail is then driven into the top of the wood stake to mark the exact reference point. It may be necessary to use a large wooden stake (4" x 4" x 6') or a steel bar where the ground is unstable or if the reference points are to be used on a long-term basis.

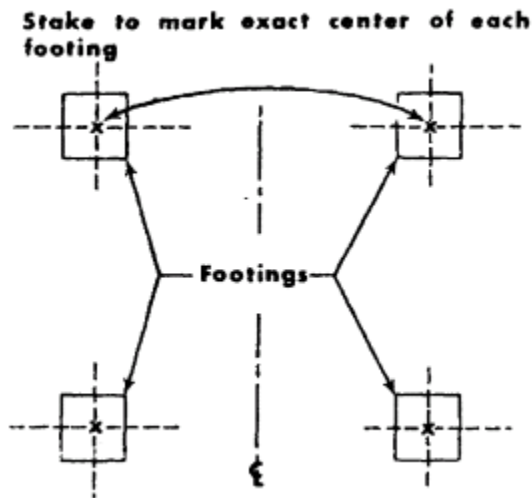

Guard stakes are usually 1" x 2" x 14" wood stakes driven into the ground next to the hub or iron pin. A lathe with colored flagging tied to the top can also be set near the reference point to mark the location.

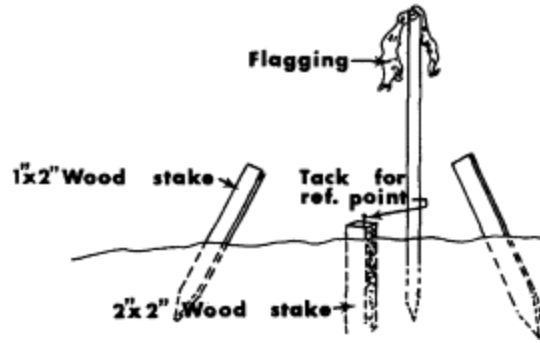

Each reference and offset stake should be identified. The description and location can be written on one or both guard stakes placed beside the point. (see sketch below) Note if centerline of roadway or bridge was intended.

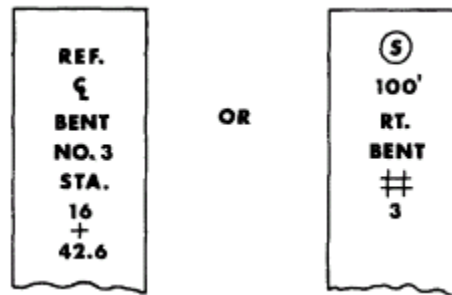

c. Benchmarks

A minimum of four benchmarks (BM) shall be established outside the work limits at the structure site. It is desirable to establish two BM's to check the deck area, and two BM's to check the footings.

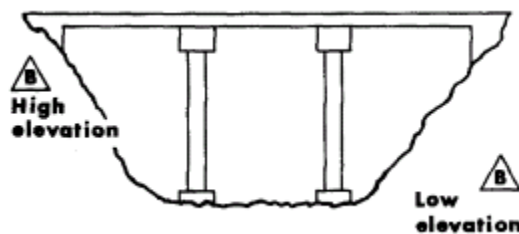

The elevation of the newly set benchmarks should be established by running a level loop starting from and leveling through a minimum of two previously established project primary control, County benchmarks or NGS benchmarks.

PUBLIC LANDS SURVEY SYSTEM CORNERS

State and Federal statutes are clear concerning the preservation, restoration and recording of Public Lands Survey System (PLSS) corners. These corners must be restored; and certified corner records filed to insure the PLSS corners within SDDOT right of way will not be lost or obliterated due to the construction of highways. This work is to be performed by or under the direction of a Land Surveyor licensed in the State of South Dakota.

a. Reconstruction Projects

Public Lands Survey System (PLSS) monuments will be set, reestablished or verified along the project following the completion of all surfacing and fencing operations for each phase of the construction project.

- i) The appropriate Region Land Surveyor will provide the following:
 - 1. Set Corner plans showing the symbol and point number of all PLSS corners to be set, reestablished or verified along the project.
 - 2. Set corner report in a comma separated value (CSV) format showing; point number, northing, easting, average project elevation, type of monument and description of monument for each PLSS corner to be set, reestablished or verified along the project.

For Contractor Staking; aluminum caps (2" diameter), rebar (5/8" diameter x 18" long) and all other materials associated with the completion of this work will be incidental to the contract unit price per each for "Reestablish Public Lands Survey System corners".

- ii) PLSS corners will be monumented with a rebar and aluminum cap unless circumstances justify the use of other suitable monumentation. Substitute monuments shall be permitted only when approved by the appropriate SDDOT Region Land Surveyor. PLSS monuments will be set, reestablished or verified at the following locations:
 - 1. Section corner locations
 - 2. Quarter section corner locations
 - 3. Minor aliquot subdivision corner locations (1/16th, 1/64th, interior 1/4, etc.)
- iii) A minimum of two suitable accessories shall be referenced or two reference monuments shall be established within the right of way corridor in proximity to the right of way fence or right of way line. Driving a painted steel fence post adjacent to the reference monuments will provide protection and allow relocation in future surveys.

- iv) When PLSS corners cannot be occupied and monumented in the usual manner or where the monument would be susceptible to destruction; accessories or reference monuments will be established as stated in **iii)** above.
- v) A stakeout report will be submitted to the appropriate SDDOT Region Land Surveyor for QA & QC purposes at the completion of PLSS corner staking for each phase of the construction project. The stakeout report, in the same format as the provided set corner report, will contain updated coordinates for the following:
 - 1. Set, reestablished or verified section corner monuments
 - 2. Set, reestablished or verified quarter section corner monuments
 - 3. Minor aliquot subdivision monuments (1/16th, 1/64th, interior 1/4, etc.)
 - 4. Reference monuments and or accessories referencing the section corner, quarter corner and minor aliquot subdivision corner
- vi) Per SDCL 43-20-3; A certified land corner record will be prepared and filed with the Register of Deeds of the County in which the PLSS corner is located, unless the monument and accessories are substantially as described in an existing corner record on file in the Register of Deed Office.
- vii) A copy of the recorded certified land corner record will be submitted to the appropriate SDDOT Region Land Surveyor for SDDOT archive purposes.

Deviating from the above outlined **Reconstruction Projects** process will require approval by the appropriate SDDOT Region Land Surveyor.

b. Resurfacing, Restoration and Rehabilitation Projects

Public Lands Survey System (PLSS) monuments will be located, properly recorded and reestablished along the project within the existing SDDOT right of way.

- i) Prior to any construction activities - PLSS monuments will be located, state plane coordinates recorded and verified at the following locations within the highway right of way:
 - 1. Section corner locations
 - 2. Quarter section corner locations
 - 3. Minor aliquot subdivision corner locations (1/16th, 1/64th, interior 1/4, etc.)

Remember it may be several months to a year before the PLSS monuments can be reestablished and permanent reference monuments set on the project. Changes in land use and SDDOT staff may make reestablishment difficult if coordinates are not properly obtained and complete notes kept. Care is to be taken in acquiring coordinates to assure precise and accurate state plane coordinates are obtained for each PLSS corner position.

- ii) Following the completion of all surfacing operations - PLSS corners will be reestablished according to the state plane coordinates obtained prior to construction activities. The PLSS corners will be monumented with a rebar and aluminum cap unless circumstances justify the use of other suitable monumentation. Substitute monuments shall be permitted only when approved by the appropriate SDDOT Region Land Surveyor.

For Contractor Staking; aluminum caps (2" diameter), rebar (5/8" diameter x 18" long) and all other materials associated with the completion of this work will be incidental to the contract unit price per each for "Reestablish Public Lands Survey System corners".

- iii) A minimum of two suitable accessories shall be referenced or two reference monuments shall be established within the right of way corridor in proximity to the right of way fence or right of way line. Driving a painted steel fence post adjacent to the reference monuments will provide protection and allow relocation in future surveys.
- iv) When PLSS corners cannot be occupied and monumented in the usual manner or where the monument would be susceptible to destruction; accessories or reference monuments will be established as stated in **iii)** above.
- v) A stakeout report will be submitted to the appropriate SDDOT Region Land Survey for QA & QC purposes at the completion of PLSS corner staking for each phase of the construction project. The stakeout report, in a comma separated value (CSV) format, will contain updated state plane coordinates for the following:
 - 1. Section corner monuments
 - 2. Quarter section corner monuments
 - 3. Minor aliquot subdivision monuments (1/16th, 1/64th, interior 1/4, etc.)
 - 4. Reference monuments and or accessories referencing the section corner, quarter corner and minor aliquot subdivision corner
- vi) Per SDCL 43-20-3; A certified land corner record will be prepared and filed with the Register of Deeds of the County in which the PLSS corner is located, unless the monument and accessories are substantially as described in an existing corner record on file in the Register of Deed Office.
- vii) A copy of the recorded certified land corner record will be submitted to the appropriate SDDOT Region Land Surveyor for SDDOT archive purposes.

Deviating from the above outlined **Resurfacing, Restoration and Rehabilitation Projects** process will require approval by the appropriate SDDOT Region Land Surveyor.

RIGHT OF WAY AND PROPERTY CORNERS

State statutes are clear concerning the platting, setting and preservation of right of way and property corners. These corners must be set or reestablished and plats filed to insure SDDOT right of way is clearly marked on the ground and private property corners preserved. This work is to be performed by or under the direction of a Land Surveyor licensed in the State of South Dakota.

a. Reconstruction Projects

Right of way (ROW) monuments and property monuments will be set, reestablished or verified along the project following the completion of all surfacing and fencing operations for each phase of the construction project.

- i) The appropriate SDDOT Region Land Surveyor will provide the following:
 1. Set Corner plans showing the symbol and point number of all right of way and property corners to be set, reestablished or verified along the project.
 2. Set corner report in a comma separated value (CSV) format showing; point number, northing, easting, average project elevation, type of monument and description of monument for each right of way and property corner to be set, reestablished or verified along the project.
 3. Aluminum caps stamped "SD DOT HIGHWAY R.O.W."
 4. Green plastic caps stamped "SOUTH DAKOTA DEPT OF TRANS"
 5. Carsonite guard posts will be provided for ROW corners in rural areas.

For Contractor Staking; rebar (5/8" diameter x 18" long) and all other materials associated with the completion of this work will be incidental to the contract unit price per each for "Reestablish right of way and property corners".

- ii) Right of way corners will be monumented with a rebar and "SDDOT HIGHWAY R.O.W." aluminum cap unless circumstances justify the use of other suitable monumentation. Substitute monuments shall be permitted only when approved by the appropriate SDDOT Region Land Surveyor. Right of way monuments will be set, reestablished or verified at the following locations:
 1. Intersection of statutory section line right of way lines with SDDOT highway right of way line.
 2. Intersection of quarter lines with SDDOT highway right of way line.
 3. Points of curvature (PC), points of tangent (PT) and angle points (AP) along the SDDOT highway right of way line.
 4. Block, Addition and Subdivision corner locations.
- iii) Property corners will be monumented with a rebar and "SOUTH DAKOTA DEPT OF TRANS" plastic cap unless circumstances justify the use of other suitable monumentation. Substitute monuments shall be permitted only when approved by

the appropriate SDDOT Region Land Surveyor. Property corner monuments will be set, reestablished or verified at the following locations:

1. The exterior boundary of platted Permanent Easements.
 2. The exterior boundary of platted SDDOT property (Excess property, Abandonment, Transfer, etc.).
 3. In areas of the project where no new right of way has been obtained - all property corner monuments found along the existing right of way line (during the land tie phase of the project) will be relocated to verify they have not been disturbed or obliterated during construction activities. If disturbed or obliterated the property corner will be reestablished and monument set in its found location according to the land ties survey.
 4. In areas of the project where new right of way has been obtained - all property corner monuments found along the existing right of way line during the land tie phase of the project will be reestablished on the new right of way line at the intersection of the property line and the new SDDOT highway right of way line.
- iv) A stakeout report will be submitted to the appropriate SDDOT Region Land Survey for QA & QC purposes at the completion of right of way corner and property corner staking for each phase of the construction project. The stakeout report, in the same format as the provided set corner report, will contain updated coordinates for the following:
1. Set, reestablished or verified right of way corner monuments
 2. Set, reestablished or verified property corner monuments

Deviating from the above outlined **RIGHT OF WAY AND PROPERTY CORNERS** process will require approval by the appropriate SDDOT Region Land Surveyor.

UNDERCUT VOLUMES

During construction, undercut volumes may be necessary if the contractor is directed to excavate below the specified undercut on the plans. Additional undercut may be necessary below structures, box culverts and pipes.

Undercutting shall consist of excavating material immediately below an upper limit as established on the plans and a lower limit as directed by the engineer. The width and length will be specified on the plans unless otherwise directed by the engineer.

Two methods for obtaining undercut volumes are as follows:

- i) Topographic survey method for topsoil stockpiles can be utilized for undercut volumes and is outlined in chapter 6 of this manual.
- ii) Average end area method requires a minimum of four cross sections.

1. The first cross section taken ahead of the undercut.
2. The second taken behind the undercut.
3. The third and fourth cross sections taken within the undercut excavation.

Additional cross sections may be necessary within the undercut excavation depending on changes in volume and the size of undercut.